

TECHNICAL SPECIFICATIONS

SFC 407 Ex/31 WB BS4 TWIN TYRE CAB WITH LOAD BODY/CAB WITHOUT LOAD BODY

POWERTRAIN

Engine Type	4SP CR Turbo Inter-cooled BS4 Water-cooled
Displacement/Cubic Capacity	2 956 cc
Max. Power Output	62.5 kW @ 2 800 r/min
Max. Torque	250 Nm @ 1 400 - 2 400 r/min
Bore x Stroke	97 mm x 100 mm
Clutch	Single Plate Dry Friction Type - 280 mm dia
Transmission	G380 Synchromesh, 5 Forward + 1 Reverse

FUEL SYSTEM

Fuel Injection System	Electronic Delphi
Fuel Tank Capacity	60 l

ELECTRICALS

Battery	12 V, 75 Ah
Alternator	75 A

PERFORMANCE

Gradeability	29 %
Max. Speed in Top Gear	96 km/h

STEERING

Steering System	Recirculating Ball Type with Rack and Sector
-----------------	--

FRAME

Frame	Ladder Type Frame with Riveted/Bolted Cross Members
-------	---

BRAKES

Service Brake	Vacuum Assisted Dual Circuit Hydraulic with Tandem Master Cylinder
Parking Brake	Cable Operated Mechanical/Spring Brake Acting on all Rear Wheels

SUSPENSION & TYRES

Front Suspension	Semi-elliptical Leaf Spring and Hydraulic Double Acting Telescopic Type Shock Absorber with Anti-roll Bar
Rear Suspension	Semi-elliptical Leaf Spring and Hydraulic Double Acting Telescopic Type Shock Absorber

No. of Tyres	Front - 2, Rear - 4, Spare - 1
Front	7.00 x 16 - 12 PR (Rib)
Rear	7.00 x 16 - 12 PR (Rib)

WEIGHT

Front Axle Weight - FAW	2 140 kg
Rear Axle Weight - RAW	3 160kg
Rated Payload	3 209 kg
Gross Vehicle Weight	5 300 kg

OVERALL DIMENSIONS

Wheelbase	3 100 mm
Length	5 050 mm
Height	2 257 mm
Width	2 016 mm

LOAD BODY DIMENSIONS

Length	NA	2 883 mm
Width	NA	1 908 mm
Side Deck Height	NA	444 mm
Platform Height	NA	980 mm
Min. Turning Radius	12 000 mm	12 000 mm
Min. Ground Clearance	187 mm	187 mm
Warranty	3-year or 3 lakh km (Whichever is earlier)	

Specifications are subject to change without prior notice. These are indicative photos, specifications for reference only.

Ex2 Delighters: Digital Clock, Portable & Clear Lens Lamp, Shirt Hook, Mobile Charger, Rear View Mirror, Utility Box & Reverse Beeper

EX

has become synonymous with high performance and superior quality

- **EXTRA REVENUE**
- **EXTRA SAVINGS**
- **EXTRA PROFITS**
- **EXTRA COMFORT**
- **EXTRA SAFETY**

Dealer Stamp

For more information, please visit our website: www.light-trucks.tatamotors.com
 You can also contact our Sales Office: Tata Motors Limited, 4th Floor, Ahura Centre, 82, Mahakali Caves Road, MIDC, Andheri (East), Mumbai - 400 093 or call toll-free no. 1800 209 7979.

Terms & Conditions apply as per the policy of ITGI. Insurance available on light, intermediate & heavy commercial vehicles.
 CAUTION: Accessories shown in the picture or elsewhere do not constitute standard fitment. The specifications are merely indicative. Due to continuous product improvements, these specifications are liable to change without notice.

TATA MOTORS
Connecting Aspirations

**RELIABLE PERFORMANCE
GUARANTEED**

SFC 407 TT



India's Iconic LCVs

The right choice for the Indian market

SFC 407 TT

India's quarry specialist, rightly named as the only light truck with optimum Power & Torque, giving it the ability to mount any gradient and rule any road. The SFC 407 TT with its 4-rear tyres is extremely stable and well-equipped to handle uneven load distribution and vertical loading with ease.

SFC: ADVANTAGE

SAFE & COMFORTABLE

We understand that driving commercial vehicles is a serious business. For special applications where often speed is of the essence, the customer needs to know that he will be safe at all times. The unique 'nose' of the SFC 407 gives confidence, safety and security to the person behind the wheels.

Tata Motors is the only manufacturer in the country actively selling SFC face vehicles in the Light Commercial Vehicle segment. At Tata Motors, we believe that safety is our number one priority.

Unbeatable features that now make Tata RJ 407 even more driver-friendly

- In-built music system
- Heat-resistant seat fabric
- Mobile charging socket
- More storage space inside cabin
- Heat-resistant premium Titanium White colour
- Enhanced exterior looks



LARGER LOADING AREA



LOWER TCD



BEST-IN-CLASS GRADEABILITY

SALIENT FEATURES

- Reclining and sliding driver seats
- Door handle cum armrest
- Bottle holder
- Seating capacity - Driver + 2
- Seat material - Vinyl fabric
- Engine compartment light
- Seat belt warning light for driver
- Moulded roof lining
- ELR seatbelt
- Glove box
- Roll down window
- Adjustable head rest
- Utility box under drivers seat
- Strongest & reinforced ladder type chassis frame
- Low loading platform height of 983 mm for ease in loading and unloading
- Largest loading area of 5.58 sq m - best in its class
- Battery charge indication lamp
- Engine oil low pressure indicator light
- Speed limiting on ECU
- High gradeability and excellent stability in off-road conditions
- Stylish front grill with chrome

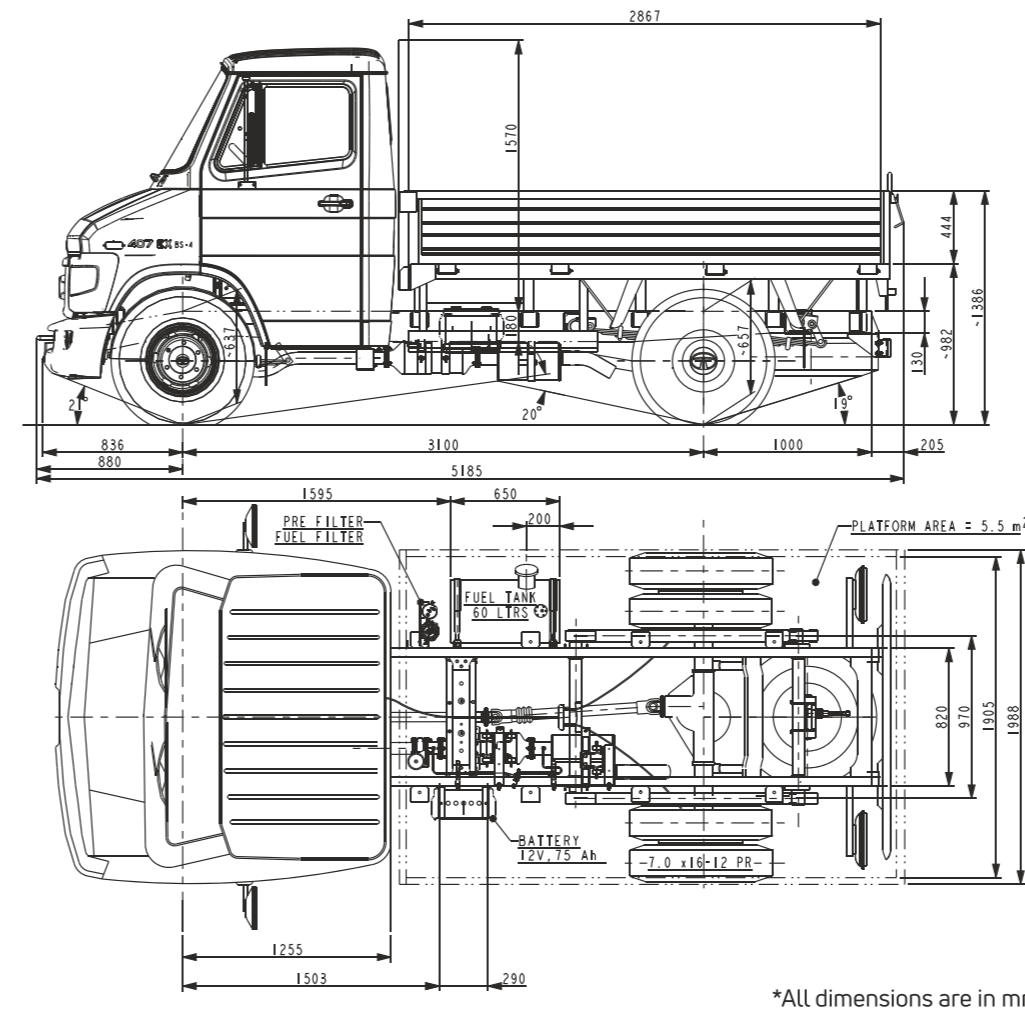

*All dimensions are in mm

MOST FUEL EFFICIENT AND POWERFUL ENGINE

TATA 4SP CR TURBO INTER-COOLED

- Reliable 4SP CR with Turbo Inter-cooled Technology
- 62.5 kW; 250Nm - Optimised for Best-in-class Mileage
- Largest Clutch Plate (280 mm) in Segment
- BS4 Compliant



TRIED, TESTED & TRUSTED

- Reliable 4SP CR engine
- High horsepower and torque
- Heavy duty aggregates
- Lowest spare parts cost
- Most cost-efficient in its class
- Highest resale value
- Largest customer base

ALL-SEASON MANY APPLICATIONS



Poultry



Poultry Feed



Food Grain Bags



Water Tanker



Parcel and Courier



FMCG