

TECHNICAL SPECIFICATIONS

LPT 407 Ex2/38 WB, 4SP CR BS4 Single Tyre with Air Brake Cab & High Deck Load Body 3 800

POWERTRAIN

Engine Type 4SP CR Turbo Inter-cooled BS4
 Displacement/Cubic Capacity 2 956 cc
 Max. Power Output 62.5 kW @ 2 800 r/min
 Max. Torque 250 Nm @ 1 400 - 2 400 r/min
 Bore x Stroke 97 mm x 100 mm
 Clutch Single Plate Dry Friction Type - 280 mm dia
 Transmission GBS27 Synchronesh, 5 Forward + 1 Reverse

FUEL SYSTEM

Fuel Injection System Electronic Delphi
 Fuel Tank Capacity 60 L

ELECTRICALS

Battery 12 V, 75 Ah
 Alternator 75 A

PERFORMANCE

Gradeability 25 %
 Max. Speed in Top Gear 94 km/h

STEERING

Steering System Integral Hydraulic Assisted Power Steering

FRAME

Frame Ladder Type Frame with Riveted/Bolted Cross Members

BRAKES

Service Brake Dual Circuit Full Air S-Cam Brakes
 Parking Brake Cable Operated Mechanical

SUSPENSION & TYRES

Front Suspension Semi-elliptical Leaf Spring and Hydraulic Double Acting Telescopic Type Shock Absorber
 Rear Suspension Semi-elliptical Leaf Spring with Auxiliary Springs and Hydraulic Double Acting Telescopic Type Shock Absorber

No. of Tyres Front - 2, Rear - 2, Spare - 1
 Front 8.25 x 16 - 16 PR Rib Type
 Rear 8.25 x 16 - 16 PR Lug Type

WEIGHT

Front Axle Weight - FAW 3 500 kg
 Rear Axle Weight - RAW 3 800 kg
 Gross Vehicle Weight 7 300 kg

OVERALL DIMENSIONS

Wheelbase 3 800 mm
 Length 6 075 mm
 Height 2 360 mm
 Width 2 140 mm

LOAD BODY DIMENSIONS

Length NA
 Width NA
 Side Deck Height NA
 Loading Platform Height 1 055 mm
 Min. Turning Dia 13 500 mm
 Min. Ground Clearance 230 mm
 Warranty 3-year or 3 lakh km (Whichever is earlier)

Specifications are subject to change without prior notice. These are indicative photos, specifications for reference only.

Ex2 Delighters: Digital Clock, Portable & Clear Lens Lamp, Shirt Hook, Mobile Charger, Rear View Mirror, Utility Box & Reverse Beeper



	CAB	CLB	HD
Front Axle Weight - FAW	3 500 kg	3 500 kg	3 500 kg
Rear Axle Weight - RAW	3 800 kg	3 800 kg	3 800 kg
Gross Vehicle Weight	7 300 kg	7 300 kg	7 300 kg
Wheelbase	3 800 mm	3 800 mm	3 800 mm
Length	6 075 mm	6 075 mm	6 075 mm
Height	2 360 mm	2 360 mm	3 000 mm
Width	2 140 mm	2 140 mm	2 140 mm
Length	NA	4 168 mm	4 136 mm
Width	NA	2 035 mm	2 030 mm
Side Deck Height	NA	412 mm	1 745 mm
Loading Platform Height	1 055 mm	1 055 mm	1 055 mm
Min. Turning Dia	13 500 mm	13 500 mm	13 500 mm
Min. Ground Clearance	230 mm	230 mm	230 mm
Warranty	3-year or 3 lakh km (Whichever is earlier)		

EX

has become synonymous with high performance and superior quality



- EXTRA REVENUE
- EXTRA SAVINGS
- EXTRA PROFITS
- EXTRA COMFORT
- EXTRA SAFETY

Dealer Stamp

For more information, please visit our website: www.light-trucks.tatamotors.com
 You can also contact our Sales Office: Tata Motors Limited, 4th Floor, Ahura Centre, 82, Mahakali Caves Road, MIDC, Andheri (East), Mumbai - 400 093 or call toll-free no. 1800 209 7979.

Terms & Conditions apply as per the policy of ITGI. Insurance available on light, intermediate & heavy commercial vehicles.
 CAUTION: Accessories shown in the picture or elsewhere do not constitute standard fitment. The specifications are merely indicative. Due to continuous product improvements, these specifications are liable to change without notice.

TATA MOTORS INSURANCE
 3-YEAR/3 LAKH KM WARRANTY
 TATA FLEETMAN
 TATA DELIGHT
 TATA OK

TATA MOTORS SAMPOORNA SEVA
 AAPKE SAATHI HAR KADAM
 TOLL-FREE 1800 209 7979

TATA GENUINE PARTS
 TATA SURAKSHA
 TATA PROLIFE
 TATA KAVACH
 TATA ALERT

TATA MOTORS
 Connecting Aspirations

DRIVE YOUR BUSINESS WITH
 SUPERIOR PERFORMANCE

LPT 407 Ex2



India's Iconic LCVs

The right choice for the Indian market

LPT 407 Ex2 BS4

Designed exclusively for long road applications and maximum fuel efficiency, LPT 4T range of vehicles is the longest running LPT face of vehicles in India. With trusted 4SP CR BS4 Tata engine and reliable aggregates, you can be assured of the best return on investment for your business. The LPT 407 Ex2 BS4 is also perfect choice for e-commerce and general logistics applications.

LPT SOLUTIONS

Tata Motors range of LPT LCV trucks offers the perfect solution for all bulk application needs. With the longest loading lengths and areas in all LCV segments, the LPT 407 Ex2 combines unique design, optimum fuel efficiency, maximum performance and the best re-sale value in the LPT range.

Offering a 4SP CR Turbo Inter-cooled BS4 Engine for the mileage conscious customer, the LPT 407 Ex2 combines best-in-class features with lowest cost of operations. The LPT solutions are just perfect for your business needs.

SALIENT FEATURES

- Battery charge indication lamp
- Reclining and sliding driver seats
- Door handle cum armrest
- Bottle holder
- Seating capacity - Driver + 2
- Seat material - Vinyl fabric
- Moulded roof lining
- Engine compartment light
- Battery charge indication lamp
- Seat belt warning light for driver
- Engine oil low pressure indicator light
- Speed limiter device
- Strongest & reinforced ladder type chassis frame
- Closed pitch load body
- Clear lens head lamp
- Hand grip on load body
- Power socket
- Digital clock
- Fog lamp
- Reverse beeper
- Portable lamp
- Inner rear view mirror
- Low loading platform height of 1 055 mm for ease in loading and unloading
- Largest loading area of 9 sq. m.
- Shortest turning radius of 6.75 m. for easy maneuverability

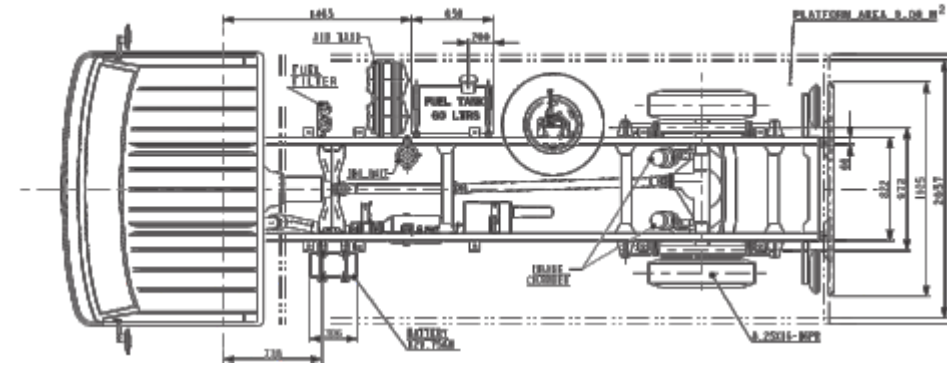
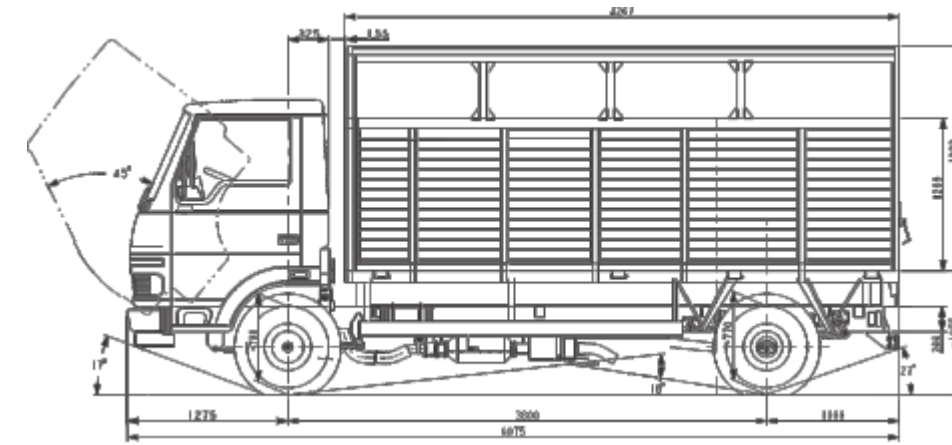

*All dimensions are in mm

MOST FUEL EFFICIENT ENGINE

TATA 4SP CR TURBO INTER-COOLED

- Reliable 4SP Engine with Common Rail Technology
- 62.5 kW, 250 Nm Optimised for Best-in-class Mileage
- Largest Clutch Plate (280 mm) in Segment
- BS4 Compliant



TRIED, TESTED & TRUSTED

- Reliable 4SP CR engine
- High horsepower and torque
- Heavy duty aggregates
- Lowest spare parts cost
- Most cost-efficient in its class
- Highest resale value
- Largest customer base

ALL-SEASON MANY APPLICATIONS



Parcels & Courier



Container



LPG



Beverages



Pipes



White Goods



Textile

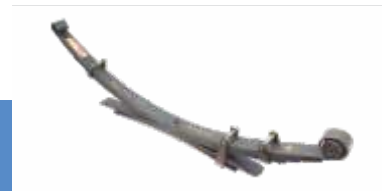

ADDITIONAL AUXILIARY SPRINGS AT REAR



AIR BRAKE FOR MORE EFFECTIVE BRAKING

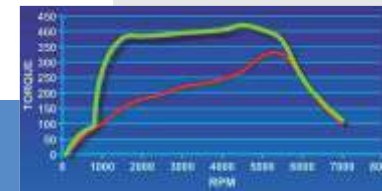

FLAT TORQUE CURVE THUS LESS GEAR SHIFT



BIGGER CLUTCH SIZE FOR EASY GEAR SHIFTING