

PV = Process value
SV = Set Value

TECHNICAL SPECIFICATION

INPUT SPECIFICATION:

Input Types	Input	Range
	J	0 to 600 °C,
	K	0 to 1200 °C,
	PT-100	-99 to 400 °C,
	PT.1	-99.9 to 400.0 °C,
Resolution	J,K,PT-100 = 1 °C	
	PT.1 = 0.1 °C	
Indication Accuracy	±1% of FSD ± 1 °C	

DISPLAY AND KEYS:

Display	Upper: 4 digit, 7 segment, 0.56" Red Lower: 4 digit, 7 segment, 0.33" Green
Keys	SET, INC, DEC, ENT

DIMENSION:

Size	96 (H) x 48 (W) x 85 (D) mm
Panel Cutout	92 (H) x 44 (W) mm

CONTROL METHOD:

Heating	1) PID control with Auto-Tuning 2) (TP) Time Proportional 3) ON-OFF control
Cooling	1) BL.TP (Blower Time Proportional) 2) ON-OFF control

OUTPUT SPECIFICATION:

Relay Output	
Relay	2 nos.
Relay Type	1 C/O , (NO-C-NC)
Rating	10A, 230V AC / 12 V DC
SSR Drive Output	
Output Signal	12V DC, 10mA DC (ON-OFF Condition)
Relay 1 Parallel to SSR	

FACTORY SETTING

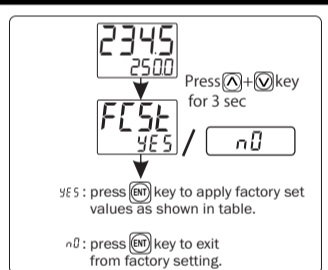

FACTORY SETTING

SR.	PARAMETER	VALUES
1	PB	20.0 °C
2	IT	300
3	DT	75
4	CT	15 sec
5	PB-2	5 °C
6	CT-2	8 Sec
7	MR	0 °C
8	OFFSET	0 °C
9	HYSTERISIS-1	3 °C
10	HYSTERISIS-2	3 °C
11	C-PB	4.0 °C
12	C-ON	1 Sec
13	C-OFF	48 Sec

PARAMETER MESSAGE DESCRIPTION

SEt 1	Set Point 1 For O/P 1
SEt 2	Set Point 2 For O/P 2
LO:1	Low Set Point 1
HI G1	High Set Point 1
LO:2	Low Set Point 2
HI G2	High Set Point 2
PRSS	Password
i nPt	Input (Sensor)
SHrP5	Soak Passing
SHrG	Soak Remaining
SHrN	Soak Time Normal
SLL	Set Low Limit
SHL	Set High Limit
DFSt	Offset
Pb	Proportional Band For PID Action
i t	Integral Time Constant
d t	Derivative Time Constant
Ct	Cycle Time For PID Action
Pb2	Proportional Band For TP Action
Ct2	Cycle Time For TP Action
r r	Manual Reset

POWER SUPPLY:

Supply voltage	100 to 250V AC, 50-60Hz
Power consumption (VA RATING)	Approx 4VA @ 230V AC MAX

ENVIRONMENT CONDITION:

Operating Temp.	0 °C to 55 °C
Relative Humidity	UP to 95% RH (non-condensing)
Protection Level (As per request)	IP-65 (Front side) As per IS/IEC 60529 : 2001

MECHANICAL INSTALLATION

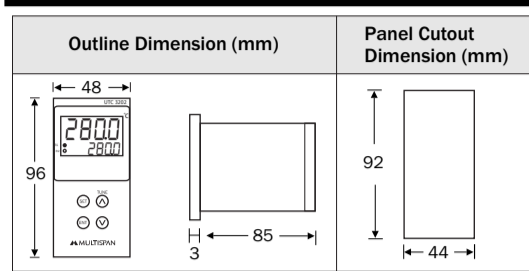

TERMINAL CONNECTION

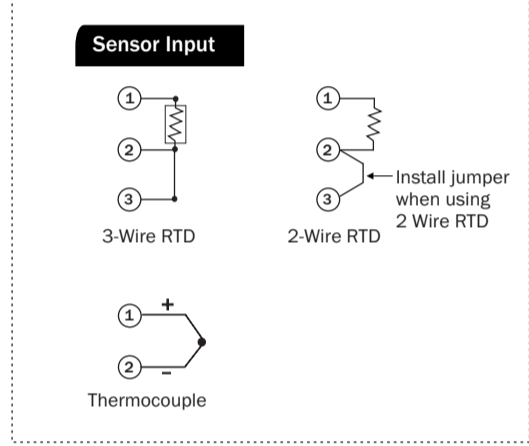
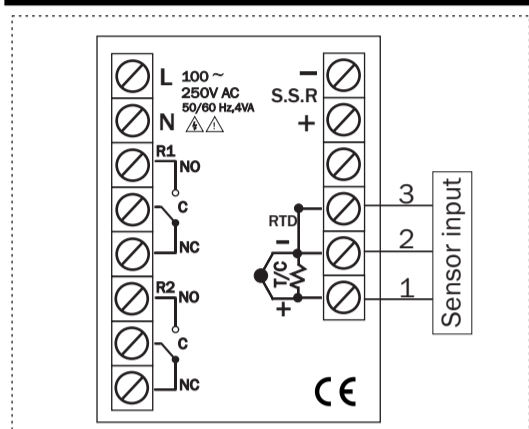

STATUS LED DESCRIPTION

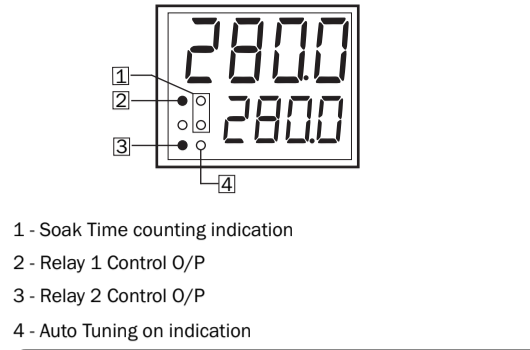

KEY OPERATION

FUNCTION	PRESS KEY
OPERATOR MODE	
To enter in parameter setting	SET
For start/stop PID auto tuning	TUNE Press 6 sec
To go in factory setting mode	TUNE + ENT Press 3 sec
To reset process after soak time end	ENT
PARAMETER SETTING MODE	
To set parameter value and move to the next parameter	SET
To increment parameter value.	TUNE
To decrement parameter value.	ENT
Set parameter to be save & exit.	ENT

SAFETY PRECAUTION

All safety related codifications, symbols and instructions that appear in this operating manual or on the equipment must be strictly followed to ensure the safety of the operating personnel as well as the instrument.

If all the equipment is not handled in a manner specified by the manufacturer, it might impair the protection provided by the equipment.

Read complete instructions prior to installation and operation of the unit.

WARNING : Risk of electric shock.

WARNING GUIDELINES

- WARNING : Risk of electric shock.**
- To prevent the risk of electric shock, power supply to the equipment must be kept OFF while doing the wiring arrangement. Do not touch the terminals while power is being supplied.
 - To reduce electro magnetic interference, use wire with adequate rating and twists of the same of equal size shall be made with shortest connection.
 - Cable used for connection to power source, must have a cross section of 1mm or greater. These wires should have insulations capacity made of at least 1.5kV.
 - When extending the thermocouple lead wires, always use thermocouple compensation wires for wiring for the RTD type, use a wiring material with a small lead resistance (5Ω max per line) and no resistance differentials among three wires should be present.
 - A better anti-noise effect can be expected by using standard power supply cable for the instrument.

INSTALLATION GUIDELINES

- This equipment, being built-in-type, normally becomes a part of main control panel and in such case the terminals do not remain accessible to the end user after installation and internal wiring.
- Do not allow pieces of metal, wire clippings, or fine metallic fillings from installation to enter the product or else it may lead to a safety hazard that may in turn endanger life or cause electrical shock to the operator.
- Circuit breaker or mains switch must be installed between power source and supply terminal to facilitate power 'ON' or 'OFF' function. However this mains switch or circuit breaker must be installed at convenient place normally accessible to the operator.
- Use and store the instrument within the specified ambient temperature and humidity ranges as mentioned in this manual.

MECHANICAL INSTALLATION GUIDELINES

- Prepare the panel cutout with proper dimensions as shown above.
- Fit the unit into the panel with the help of clamp given.
- The equipment in its installed state must not come in close proximity to any heating source, caustic vapors, oil steam, or other unwanted process byproducts.
- Use the specified size of crimp terminal (M3.5 screws) to wire the terminal block. Tightening the screws on the terminal block using the tightening torque of the range of 1.2 N.m.
- Do not connect anything to unused terminals.

MAINTENANCE

- The equipment should be cleaned regularly to avoid blockage of ventilating parts.
- Clean the equipment with a clean soft cloth. Do not use isopropyl alcohol or any other cleaning agent.
- Fusible resistor must not be replaced by operator.

PARAMETER MESSAGE DESCRIPTION

C-Pb	Cooling PB
C-On	Cooling On Time
C-Of	Cooling Off Time
HYS 1	Hysteresis 1
HYS 2	Hysteresis 2
r1 m	Relay 1 Mode
SOAP	Soak Time Select
SHrP	Soak Mode
SHrU	Soak Unit
SHrN	Soak Time Value
SHrM	Soak Time Memory
End	Soak Time End
Ctr 1	Control Action 1
Ctr 2	Control Action 2
AL 1	Alarm 1
AL 2	Alarm 2
Set 2	Set 2 Mode
r1 dL	Relay 1 Delay Time
r2 dL	Relay 2 Delay Time
AL t	Alarm Time
Pi d	PID Action
TP	TP Action
OnOff	ON-OFF Action
BL TP	Blower TP Action
HI G1	High Alarm
Ab-L	Absolute Low Alarm
i n-b	In Band Alarm
Ab-O	Absolute Out Band Alarm
HEAt	Heating Mode
COOL	Cooling Mode
AL r	Alarming Mode
OFF	OFF Mode
YES	Yes
n0	No
SAvE	Save
i nd1	Set 2 Individual to Set 1
rLt u	Set 2 Reletive to Set 1
SEC	Second
min	Minute
HOu r	Hour
FCSE	Factory Setting

RANGE FOR CONTROL PARAMETER

Parameter	Range for J, K, PT100	Range for PT.1 sensor
PB	0.0 to 999.9 °C	0.0 to 999.9 °C
IT	0 to 9999	0 to 9999
DT	0 to 9999	0 to 9999
CT	4 to 99 sec	4 to 99 sec
Pb2	2 to 20 °C	2.0 to 20.0 °C
Ct2	4 to 99 sec	4 to 99 sec
MR	-9 to 9 °C	-9.0 to 9.0 °C
OFFSET	-20 to 20 °C	-20.0 to +20.0 °C
HYS1	1 to 100 °C	0.1 to 100.0 °C
HYS2	1 to 100 °C	0.1 to 100.0 °C
C-PB	2.0 to 25.0 °C	2.0 to 25.0 °C
C-ON	1 to 20 sec	1 to 20 sec
C-OFF	5 to 200 sec	5 to 200 sec
R1DL	0.0 to 99.59 (mm.ss)	0.0 to 99.59 (mm.ss)
R2DL	0.0 to 99.59 (mm.ss)	0.0 to 99.59 (mm.ss)
ALTM	0 to 99 sec	0 to 99 sec

ERROR DISPLAY

When an error has occurred the display indicates error codes as given below.

ERROR	MEANING
OPEn	Sensor is not connected or Over range condition or sensor break
SrE	Sensor connection is reversed

CORRECTIVE ACTION:

Check the sensor and the input wiring. If problem still exists, replace the sensor. And still if problem is not solved yet by the user, then please contact company person

SOAK TIME FUNCTION

- Soak feature can be use to hold the process at a preset temperature for a preset time. (Range : selectable up to 0 to 999 hour)

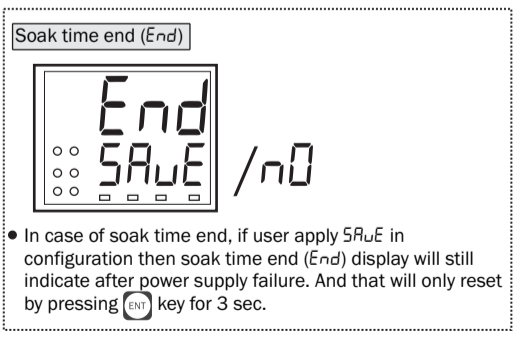
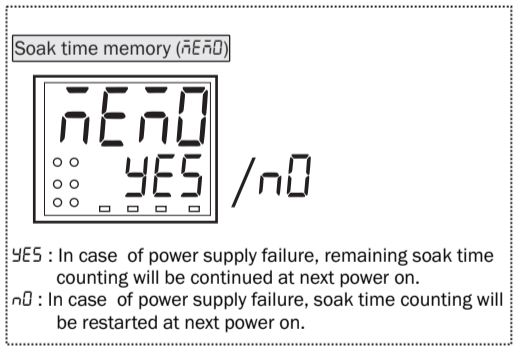
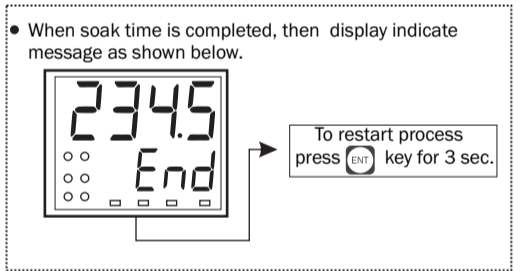

SET POINT SETTING

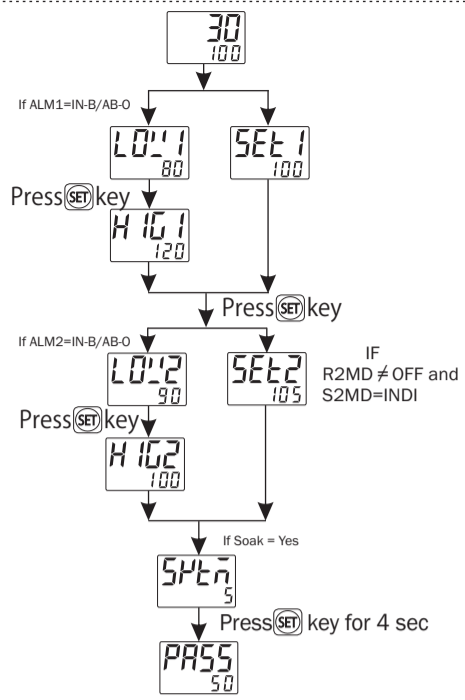

BASIC CONFIGURATION

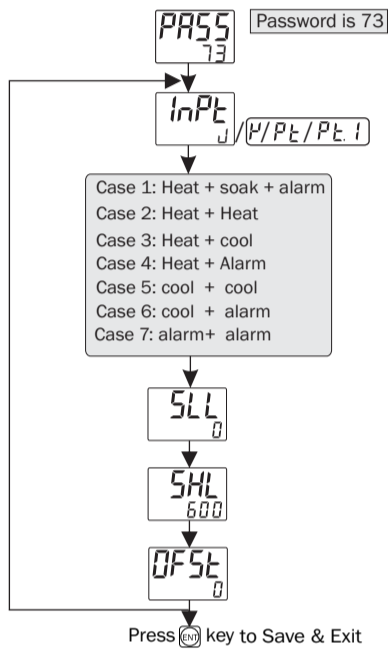

CONTROL PARAMETER SETTING

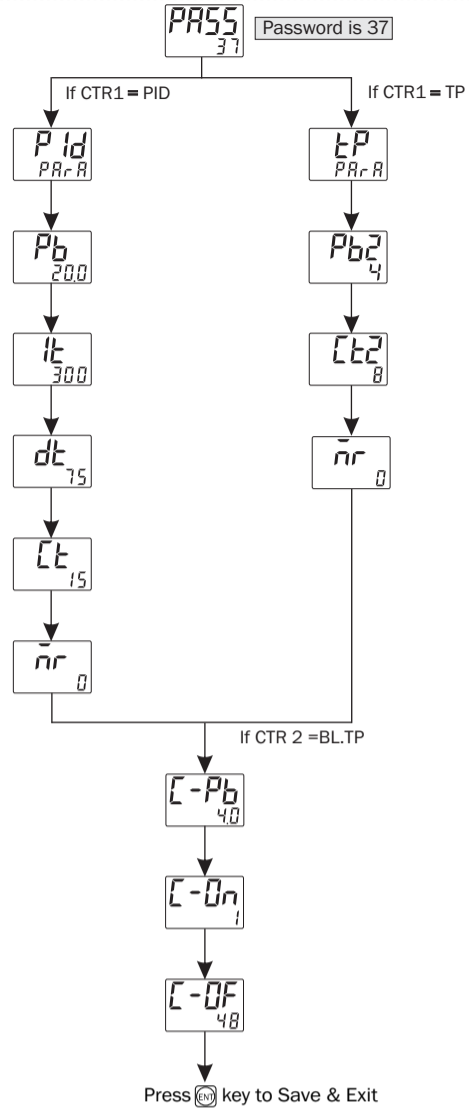

Case - 1 (Heat + Soak + Alarm)

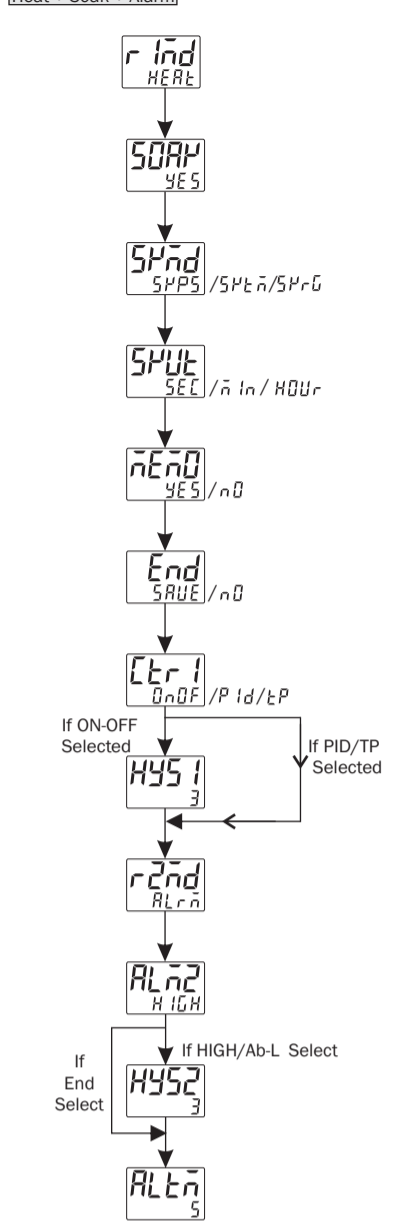

Case - 2 (Heat + Heat)

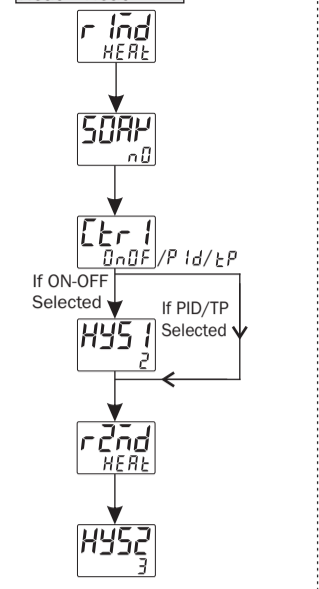

Case - 3 (Heat + Cool)

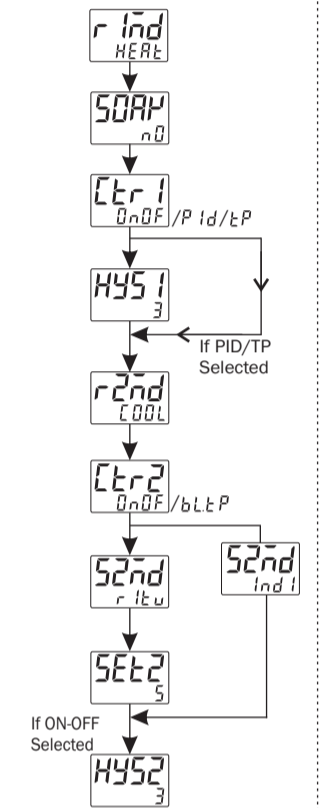

Case - 4 (Heat + Alarm)

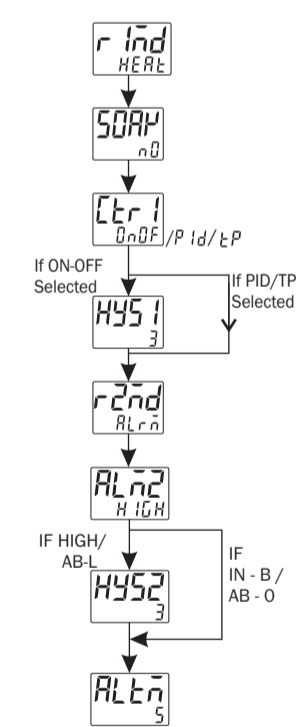

Case - 5 (Cool + Cool)

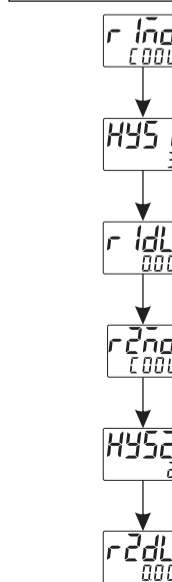

Case - 6 (Cool + Alarm)

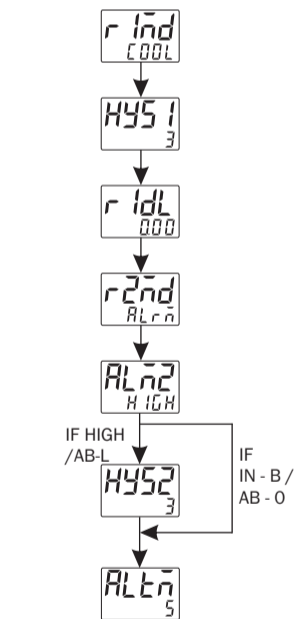

Case - 7 (Alarm + Alarm)

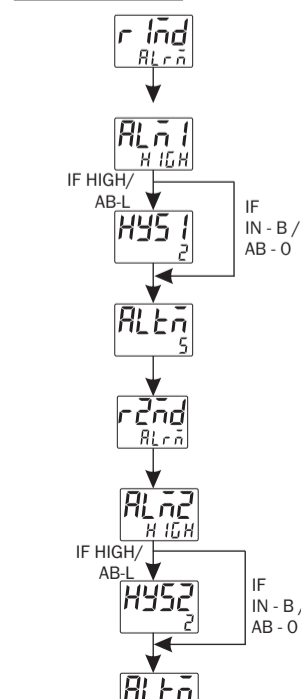

CONTROL FUNCTION

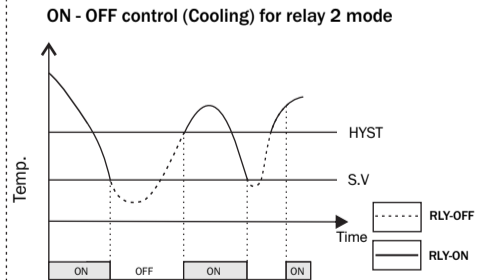
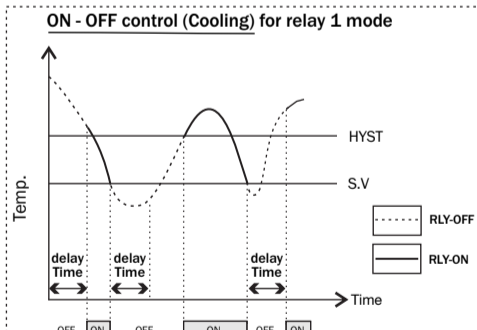
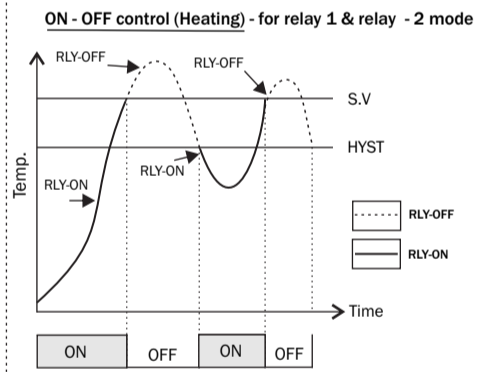

Auto Tuning:-

- The Auto-tuning function automatically computes and sets the Proportional band (Pb), Integral time (It), Derivative time (dt), and cycle time as per process characteristics.
- Tuning LED will turn "ON" during Auto-Tuning
- If the power goes off before auto-tuning is completed, auto-tuning will be restarted at next power ON.

