

Technical Specification

Model	UTC 1202	UTC 2202
Display	UPPER:- 4 Digit 7 seg 0.70",red LED Display LOWER:- 4 Digit 7 seg 0.50",green LED Display	
Size(HXWXD)	96 X 96 X 50 mm	72 X 72 X 85 mm
Panel Cutout	92 X 92 mm	68 X 68 mm
Input	J, K, PT-100 (selectable)	
Temperature Range	J: 0 to 600°C / K: 0 to 1200°C / PT-100: -99 to 400°C /PT.1: -99.0 to 400.0°C	
Control Action	PID /TP/ ON-OFF (selectable)	
Output	2 relay, 1 C/O contact, 230V AC, 5A ; 1 SSR,12V DC, 30mA DC	
Power Supply	100 to 250V AC, 50 / 60 Hz, Approx 4VA	
Protection Level (As per request)	IP-65(Front side) AS per IS/IEC 60529:2001	
Operating Temperature	0°C To 55°C	Relative Humidity Up to 95% RH Non Condensing

Note:

- 1) If Sensor Connection is reversed, Display will show "S-E" message.
- 2) If Sensor is not connected, Display will show OPEN message.
- 3) Every time the instrument is turned ON, Following pattern will be displayed

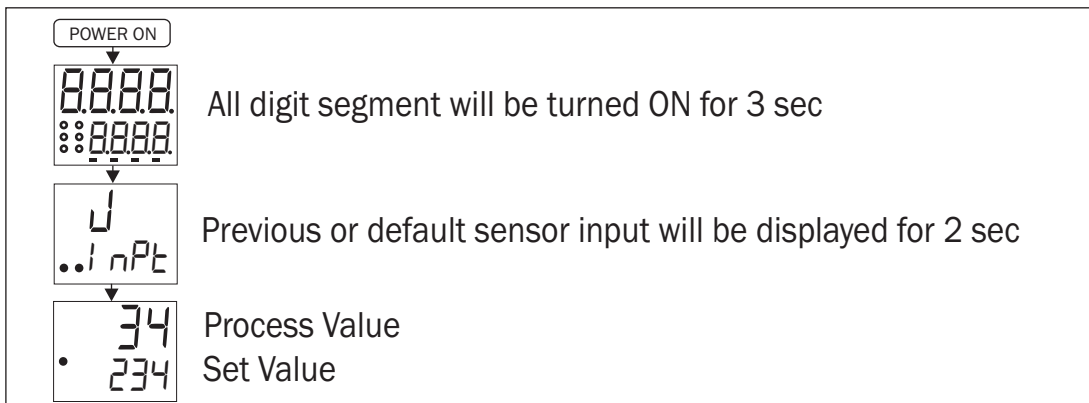

Connection Diagram

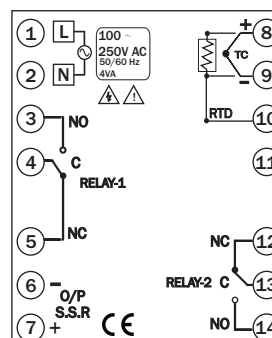
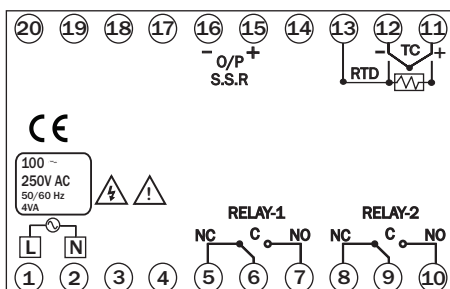

Key Operation

- 1) Press **SET** key to go parameter setting.
- 2) Press **▲** or **▼** key to change value or to select option.
- 3) Press **ENT** key to save change in setting
- 4) Press **▲** key for 6 sec to start/stop PID AUTO TUNING
- 5) Press **▲** + **▼** key for 3 sec to go to factory setting mode.
- 6) Orange color LED glows during auto tuning mode.

Set Point Setting

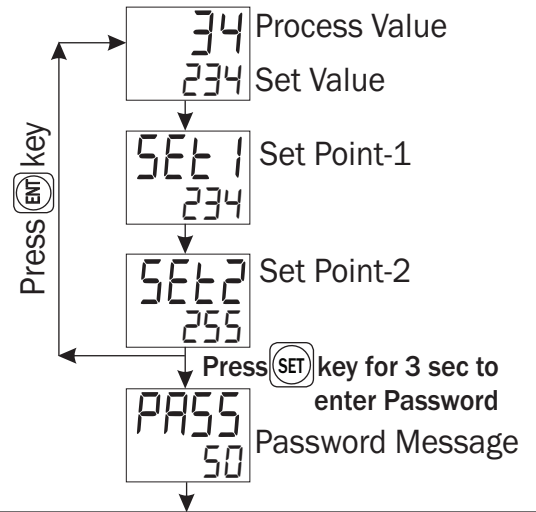

Basic Configuration

TO ENTER BASIC CONFIGURATION SETTING, ENTER "73"

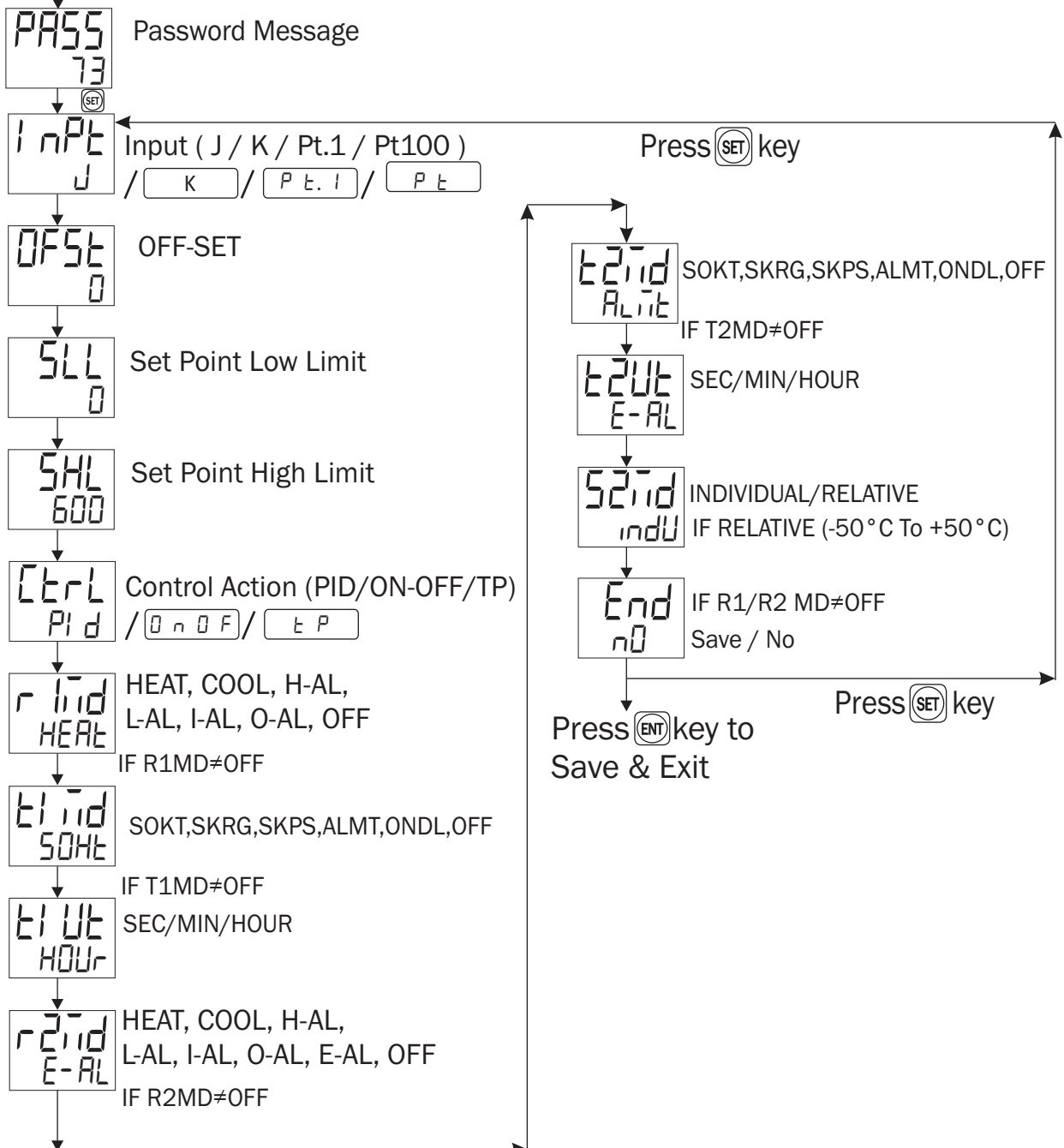

12.34 PV
 12.34 SV

PID AUTO-TUNING

Press **▲** key for 6 sec to start/stop
 PID auto-tuning

Control Parameter

TO ENTER CONTROL
 PARAMETER
 SETTING, ENTER "37"

PASS Password Message
 37

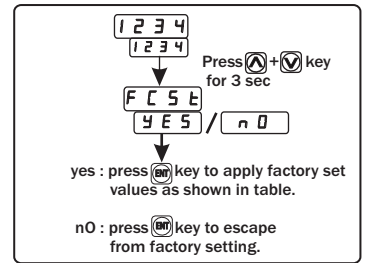

Factory Setting

FACTORY SETTING		
SR.	PARAMETER	VALUES
1	PB	20.0
2	IT	300
3	DT	75
4	CT (For PID)	15 SEC.
5	PB 2	5 °C
6	CT 2	08
7	MR	0 °C
8	OFFSET	0 °C
9	HYSTERESIS-1	3 °C
10	HYSTERESIS-2	3 °C
11	TIME-1	6 SEC
12	TIME-2	6 SEC

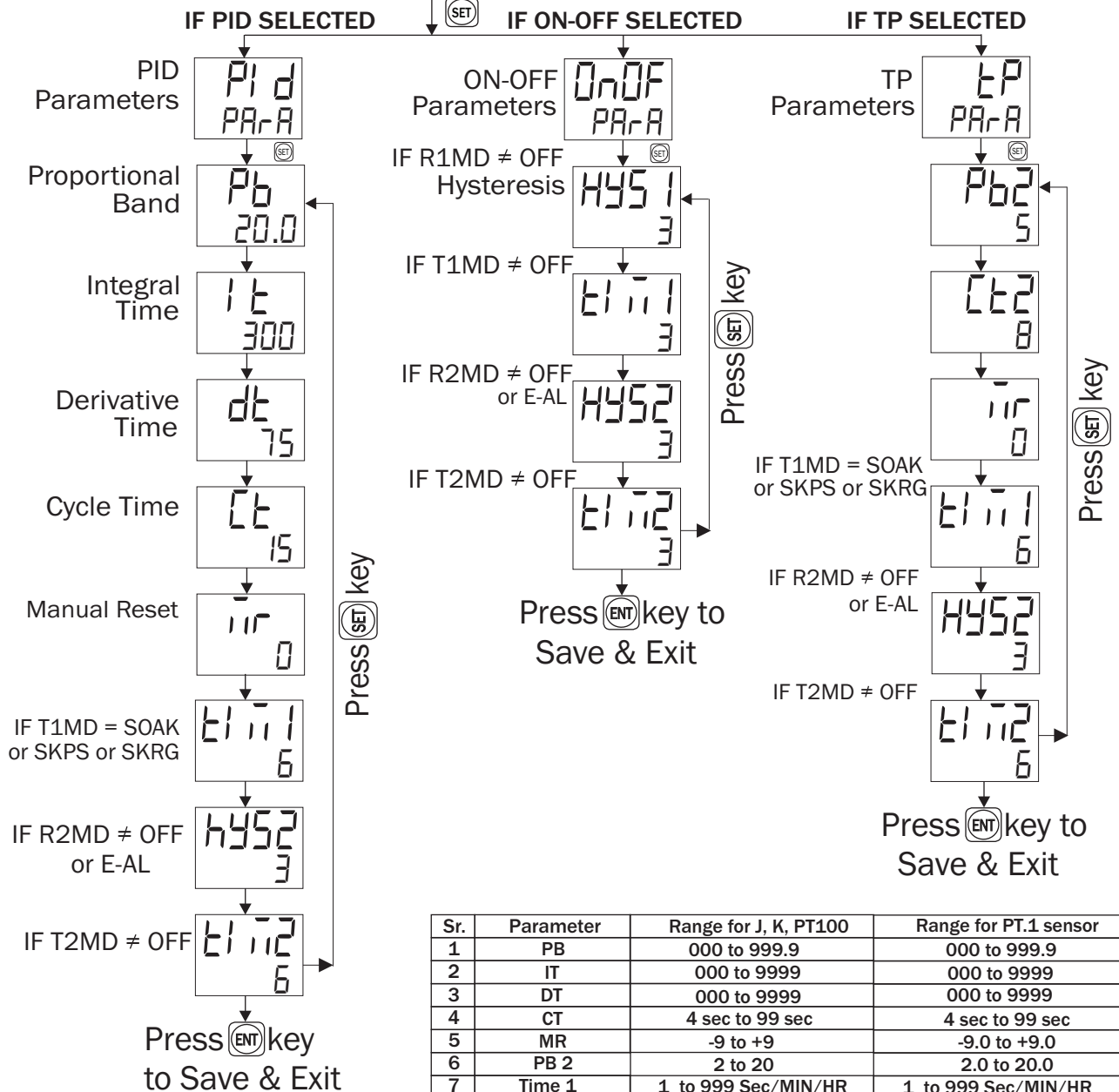

Sr.	Parameter	Range for J, K, PT100	Range for PT.1 sensor
1	PB	000 to 999.9	000 to 999.9
2	IT	000 to 9999	000 to 9999
3	DT	000 to 9999	000 to 9999
4	CT	4 sec to 99 sec	4 sec to 99 sec
5	MR	-9 to +9	-9.0 to +9.0
6	PB 2	2 to 20	2.0 to 20.0
7	Time 1	1 to 999 Sec/MIN/HR	1 to 999 Sec/MIN/HR
8	Hysteresis	1 °C to 50 °C	0.1 °C to 50.0 °C
9	Off-set correction	-20 °C to +20 °C	-20.0 °C to +20.0 °C
10	CT 2	4 Sec to 99 Sec.	4-99 Sec
11	Time 2	1 to 999 Sec/MIN/HR	1 to 999 Sec/MIN/HR

Safety Precautions

All safety related codifications, symbols and instructions that appear in this operating manual or on the equipment must be strictly followed to ensure the safety of the operating personnel as well as the instrument.

If all the equipment is not handled in a manner specified by the manufacturer, it might impair the protection provided by the equipment .

=> Read complete instructions prior to installation and operation of the unit.

 **WARNING** : Risk of electric shock.

Warning Guidelines

- 1) To prevent the risk of electric shock power supply to the equipment must be kept OFF while doing the wiring arrangement. Do not touch the terminals while power is being supplied.
- 2) To reduce electro magnetic interference, use wire with adequate rating and twists of the same of equal size shall be made with shortest connection.
- 3) Cable used for connection to power source, must have a cross section of 1mm^2 or greater. These wires should have insulations capacity made of at least 1.5kV.
- 4) When extending the thermocouple lead wires, always use thermocouple compensation wires for wiring for the RTD type, use a wiring material with a small lead resistance (5Ω max per line) and no resistance differentials among three wires should be present.
- 5) A better anti-noise effect can be expected by using standard power supply cable for the instrument.

Installation Guidelines

- 1) This equipment, being built-in-type, normally becomes a part of main control panel and such in case the terminals do not remain accessible to the end user after installation and internal wiring.
- 2) Do not allow pieces of metal, wire clippings, or fine metallic fillings from installation to enter the product or else it may lead to a safety hazard that may in turn endanger life or cause electrical shock to the operator.
- 3) Circuit breaker or mains switch must be installed between power source and supply terminal to facilitate power 'ON' or 'OFF' function. However this mains switch or circuit breaker must be installed at convenient place normally accessible to the operator.
- 4) Use and store the instrument within the specified ambient temperature and humidity ranges as mentioned in this manual.

Mechanical Installation

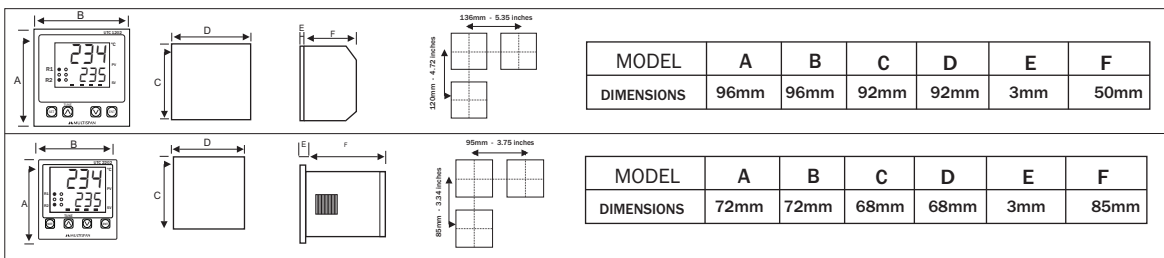

- 1) Prepare the panel cutout with proper dimensions as show above.
- 2) Fit the unit into the panel with the help of clamp given.
- 3) The equipment in its installed state must not come in close proximity to any heating source, caustic vapors, oils steam, or other unwanted process by products.
- 4) Use the specified size of crimp terminal (M3.5 screws) to wire the terminal block. Tightening the screws on the terminal block using the tightening torque of the range of 1.2 N.m.
- 5) Do not connect anything to unused terminals.

Maintenance

- 1) The equipment should be cleaned regularly to avoid blockage of ventilating parts.
- 2) Clean the equipment with a clean soft cloth. Do not use isopropyl alcohol or any other cleaning agent.
- 3) Fusible resistor must not be replaced by operator.

Product improvement and upgrade is a constant procedure. So for more updated operating information and support, Please contact our helpline : +91-9978991474/82 or Email at marketing@multispanindia.com Ver: 01-2017